

INCREASE IN THE LIFE OF WELDED JOINTS OF AMg6 ALUMINUM ALLOY

L.M. Lobanov, M.O. Pashchyn, O.M. Tymoshenko, P.V. Goncharov, O.L. Mikhodui and K.V. Shiyan

E.O. Paton Electric Welding Institute of the NAS of Ukraine

11 Kazymyr Malevych Str., 03150, Kyiv, Ukraine. E-mail: office@paton.kiev.ua

The effect of electrodynamic action on the life of welded joints of AMg6 aluminum alloy under cyclic loading was investigated. It was found that electrodynamic treatment of specimens of butt welded joints of AMg6 alloy results in reducing the level of residual tensile welding stresses, which is followed by their transition to compression. It is shown that as a result of double-sided single-channel electrodynamic surface treatment in welded joints of AMg6 alloy, the cyclic life is three times increased as compared to the initial one. Additional electrodynamic treatment of the fusion line five times increases the life as compared to the non-treated metal. In the comparative evaluation of single- and two-channel electrodynamic treatment of specimens, it was found that the increase in life when using a two-channel scheme (as compared to single-channel) is determined by the controlled synchronization of components of electrodynamic effect, which eliminates the passage of electric current pulse through its treated metal in the phase of its attenuation. It was shown that at electric pulsed action, the life of two-channel treated specimens is more than 50 % higher than that of the dynamic ones, which is connected with the contribution of electroplastic effect to the reduction of residual welding stresses. 8 Ref., 4 Tables, 5 Figures.

Keywords: electrodynamic treatment, electrode device, single- and two-channel scheme, residual welding stresses, aluminum alloys, life, electric current pulse, cycle amplitude

The use of modern ship hull and transport welded structures of aluminum-based alloys requires new approaches to increase their life. The solution to the problem of inhibiting the development of fatigue fracture is relevant for the life extension of both the new and existing machines [1].

To increase the fatigue resistance of structural materials, a number of effective ways is available based on the induction of compressive stress fields in the area of predicted fracture, among which high-frequency mechanical peening can be mentioned [2]. The methods of increasing fatigue based on reducing the stress concentration include treatment of the crack tip with pulsed electromagnetic fields of different duration and configuration [3].

One of the methods of electropulsed effects on welded joints is electrodynamic treatment (EDT) [4], the results of which are a decrease in the level of residual welding tensile stresses, which is accompanied by the formation of a layer of metal with refined structure in the treatment zone. The analysis of the results [1–4] gives grounds to suppose that EDT can be an effective way to increase the life of welded joints. At present, there are no data regarding evaluation of EDT effect on the life of welded joints.

The aim of the work was to study the effect of electrodynamic actions on the life of welded joints of aluminum AMg6 alloy under cyclic loading.

EDT of the welded joint was performed using single-channel and two-channel circuits of the electrode device (ED).

Single-channel electrode device. Design scheme of single-channel ED. The design scheme and appearance of a single-channel ED are presented accordingly in Figure 1. ED provides an electric contact between the discharge circuit and the metal treated in one channel, through which a pulse of electric current — EPC is introduced to the latter. ED provides the ability to regulate the dynamic and electropulse effects of the electrode on the metal. The working body of ED is the electrode 1 (Figure 1, a), which is fixed in the brass casing 2 with a screw 3. The working surface of the electrode, which contacts with the metal 22, is polished and has a radius of curvature being 15 mm. The casing 2, rigidly connected to the copper 8 and steel (stainless steel) 7 disks with a thickness of 3 and 5 mm together with the electrode 1 form a part of the impact mechanism (IM).

IM is fixed in two teflon sliding bearings 11, which allow them to move in the vertical direction. The rotation of the IM around its own vertical axis is prevented by two screws 4, which move in the vertical grooves of the ring 5.

The disks are connected to the housing 12, in which the inductor 10 is located, which is wound with the copper bus 6.2×1.5 mm and has 18 turns. Due to the ge-

L.M. Lobanov — <http://orcid.org/0000-0001-9296-2335>, M.O. Pashchyn — <http://orcid.org/0000-0002-2201-5137>,

O.M. Tymoshenko — <https://orcid.org/0000-0001-9163-1067>, P.V. Goncharov — <https://orcid.org/0000-0002-1980-2340>,

O.L. Mikhodui — <http://orcid.org/0000-0001-6660-7540>, K.V. Shiyan — <https://orcid.org/0000-0001-9198-6554>

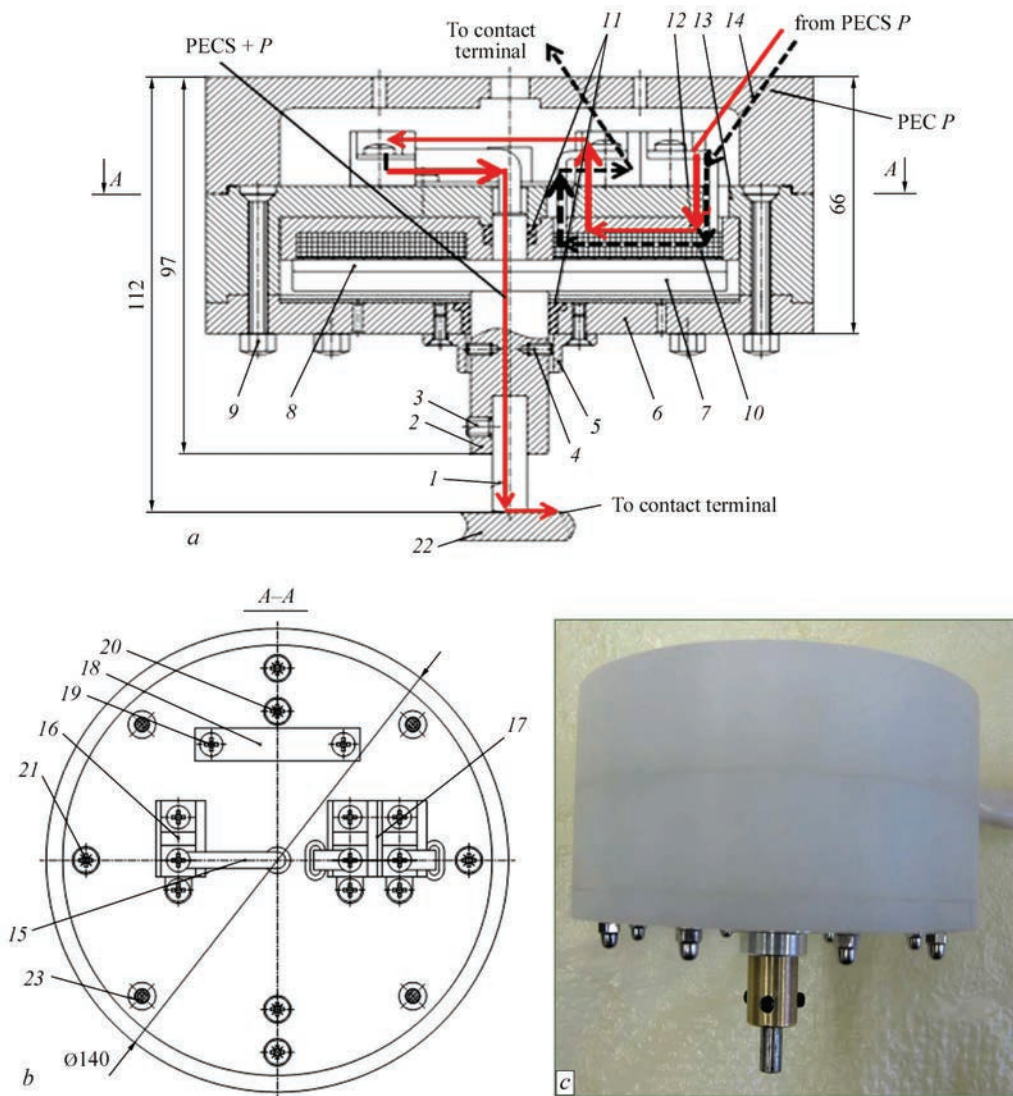

Fig re 1 Design scheme of single-channel electrode device (ED) for EDT (see explanation in the text): *a* — side view, arrows show the direction of PEC; *b* — top view; *c* — single-channel ED for EDT

ometry of the housing, between the copper disk and the winding a nonmagnetic gap of 0.5 mm is maintained. The inductance of the coil is 14.66 μH . The housing 12 is fixed on the base 13 by screws 20. From the bottom to the base 13 by screws 21 and nuts 9 the lower cover 6 is attached, on the inner surface of which, a rubber gasket is located, designed to dampen the electrodynamic impact on the lower cover when the electrode does not rest on metal. To connect the ED to the pulsed current source on top of the base 13, the terminals 16 and 17 are located (Figure 1, *b*). By means of the terminal 16, the supply of pulsed electric current (PEC) 1 to the impact mechanism through the flexible wire 15 and by the terminal 17 the winding switching are performed.

Single-channel ED has two variants of switching:

- 1) realization of interaction of electropulsed I and dynamic P effects — PEC $I + P$;
- 2) effect of only the dynamic load P — PEC P (Figure 1, *a*).

Principle of operation of single-channel ED.

During the interaction of I and P to one of the ends

of the winding of the terminal 17, the positive wire is connected from the pulsed electric current source, the other ends of the winding is connected to the impact mechanism by the terminal 16, and the negative wire from the pulsed electric current source (PECS) is connected to the treated metal 22. The scheme of PEC $I + P$ flow is shown by a solid arrow in Figure 1, *a*. Under the dynamic effect, the wire from the PECS is connected to the two ends of the terminal 17, and terminal 16 is not connected. In this case, PEC P flows in the direction indicated by the dotted arrow in Figure 1, *a*. The wires are fixed with a clamp 18, which is attached to the base 13 by means of screws 19. From the top the terminal department is closed by the cover 14 which is attached to the base by screws 20, 23 and nuts 9.

ED operates as follows. ED rests on the metal with the end of the electrode and is exposed flatwise to the treatment surface. For normal operation of ED in order to prevent sparking and melting at the place of the contact «electrode–metal» before the supply of PEC,

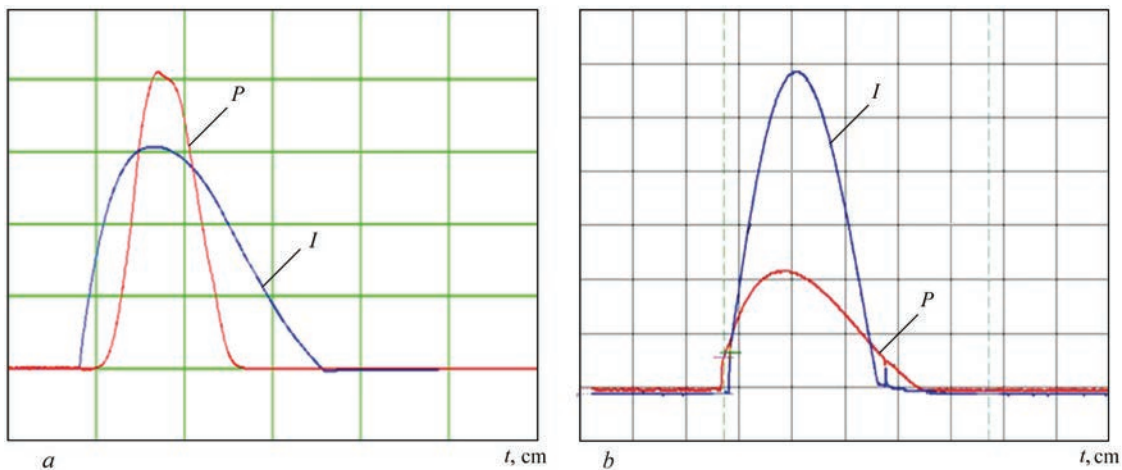

Fig re 2 Oscillograms of dynamic pressure P and pulsed current I passing through the treated metal on one-channel (a) and two-channel (b) schemes of ED

it is necessary to provide a guaranteed pressing of the electrode to the treatment surface.

At the correct positioning of ED, through the impact mechanism the load force is transmitted from the housing to the tungsten electrode and leads to pressing of the electrode to the metal surface. When PEC flows through the induction coil 10 in the disk 8 , the eddy currents are induced, at first providing the repulsion of the disk from the coil, and then at the end of the pulse — attraction to it.

Advantages of single-channel ED. The design of the single-channel ED, based on the scheme of direct passing of PEC, has a number of advantages, which include the ease of manufacturing the device and minimal energy losses in it during operation of the pulsed current source in the discharge cycle. The ED design with direct passing of PEC through the inductor and the electrode is featured by a shorter duration of the dynamic load pulse P as compared to PEC — I (Figure 2, a), as well as the lack of possibilities for a controlled synchronization of the electropulse and dynamic effects. This narrows the possibilities of controlling the EDT process, but everything is compensated by the simplicity of manufacturing and operation of ED.

From the standpoint of electrodynamics, ED with a treated welded joint, which is included in the discharge circuit with the power source, is represented in the form of magnetically coupled circuits, in the primary circuit of one of which a capacitive energy storage is included.

Two-channel electrode device. In order to eliminate the disadvantage inherent in magnetically coupled circuits, a two-channel ED based on magnetically decoupled circuits was developed and manufactured, which includes two independent channels of PEC I and PEC P . The first channel forms PEC P (Figure 2, b), which is designed to create a dynamic pressure on the treatment zone and is supplied to the induction coil of ED. The second channel forms PEC I (Figure 2, b), consistent in duration with the period of dynamic pressure on the treatment area. PEC I is supplied directly to

the electrode of ED and can be transferred to the treated switching. At the same time the scheme of ED allows switching off the second channel (PEC I) and transferring only dynamic pressure to a product. The electric circuit of the second channel is closed through a contact cable, which is attached to the product.

Design scheme of two-channel ED. As to its design, the two-channel ED (Figure 3, a) consists of the electrode 1 fixed in the housing 3 by the fixation devices 2 and 20 . The housing is connected with the disk of nonferromagnetic material 16 , which rests on the frame 6 with the inductance coil 14 placed in it with a built-in flat inductor 15 . The coil is fixed to the frame by screws 11 . The lower wall of the frame 4 , fixed by screws 5 , acts as a nonmagnetic substrate under the disk and the damper 17 . The upper (protective) cover 9 of the frame is fixed in the body of ED by screws 8 . The supply of PEC I to the coil is performed by the wire 7 . The short circuit of the discharge circuit, providing the supply of PEC I to the workpiece 18 is carried out by the terminal 19 . PEC P passes through the coil on the wires $12, 13$. The supplies $7, 12, 13$ of ED are connected to external circuits by the contact terminals 10 .

Principle of operation of two-channel ED. Two-channel ED during EDT operates as follows. When a pulsed current flows through the coil, a magnetic field is excited, which initiates eddy currents in the disk. The interaction of the induced currents with the magnetic field, by which they were initiated, leads to the generation of electrodynamic force. In the first phase of the effect, the electrodynamic force presses the electrode to the treated material, and in the second direction the force changes to the opposite one — the electrode is repelled from the treated material. The effect of the pulsed current on the treatment zone does not exceed the duration of the pressing force in terms of duration (see Figure 2, b). The design of ED is subjected to the requirements of the consistent pulse duration and the exclusion of electrospark phenomena in the treatment zone. The control of channels in

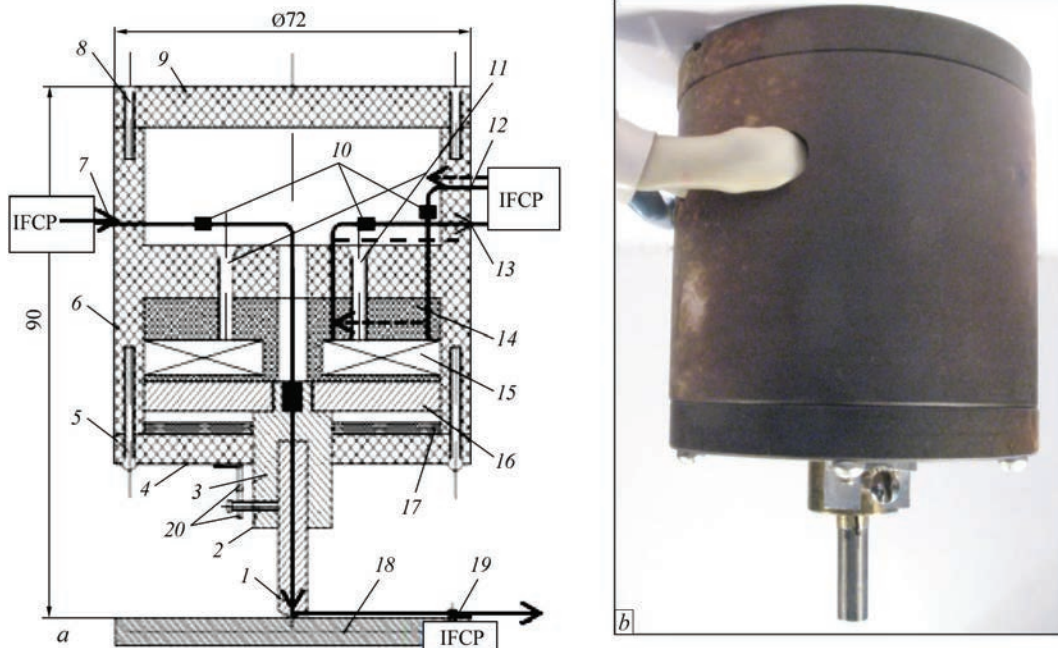

Fig re 3 Two-channel electrode device (ED) for EDT with independent PEC channels: *a* — design scheme, where the arrows show the directions of PEC *I* and PEC *P* (see explanation in the text); *b* — appearance of ED

ED is performed in three microcontrollers and on a programmable logics, which allows controlling the parameters of current pulses (amplitude), the delay of a one pulse relative to another, as well as visualizing the parameters of pulses on the light display. The duration of pulses on both channels is determined by the parameters of the electric circuit of the discharge circuits and can be changed discretely by increasing/decreasing their inductance.

Advantages of two-channel ED. To provide the normal mode of operation of ED, which eliminates sparking and melting at the point of contact «electrode-specimen», the value of static load was determined, which provides a reliable current contact of the electrode with the treated surface. For this purpose, a guaranteed static pressing of the electrode *I* of ED (Figure 1, *a*) was created to the outer surface of the specimen 22, for which the welded joint was used shown in Figure 4. On the pressing force F_y the R_c value of the electrical resistance of the contact «electrode-specimen» significantly depends. To evaluate the effect of F_y on changes of R_c , R_c values were measured by varying F_y in the range from 2 to 150 N. For this purpose, on the outer surface of the cover 14 of ED (see Figure 1, *a*), the loads of different mass were mounted and the changes in R_c values were recorded on the area of the discharge circuit between the electrode *I* and the specimen 22 with the use of the measuring bridge (LC-meter) of BR2876-5 grade. Dependence of the contact resistance R_c on the force F_y of static pressing of the electrode to the specimen is presented in Table 1, from which it is seen that with increase of F_y from 2 to 40 N, the value of the resistance R_c decreases intensively from 90 to 13 mOhm.

At a further increase in F_y to 150 N, R_c decreases linearly to 10 mOhm. From the data in Table 1 it can be concluded that an increase in F_y to more than 40 N has a negligible effect on the change in resistance in the zone of contact interaction. This determined the choice of F_y value in the subsequent experiments, which was in the range of 50–80 N.

Investigation of EDT effect on fatigue resistance of specimens of welded joints of AMg6 alloy. The specimens with a thickness $\delta = 2$ mm (Figure 5) were produced by automatic TIG (Ar) welding at an arc volt-

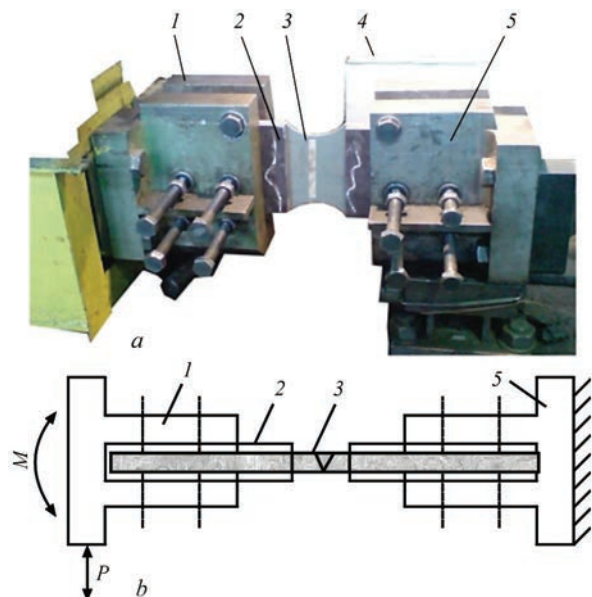

Fig re 4 Fatigue tests of specimens of welded joints of AMg6 alloy after EDT: *a* — appearance of UPM-02 testing machine (1 — movable clamp; 2 — fixing plate; 3 — specimen; 4 — cycle counter; 5 — fixed clamp); 6 — scheme of tests; *P* — horizontal load; *M* — bending moment

Table 1 Dependence of resistance of contact R_c on the force of static pressing of the electrode to the specimen F_y

F_y, N	2	3	10	15	22	40	80	150
$R_c, m\Omega$	90	40	25	20	15	13	12	10

age $U_w = 20 V$, welding current $I_w = 170 A$ and welding speed $v_w = 5.5 mm/s$. By using the method of electronic speckle interferometry [5], the values of residual welding stresses in the central elongated cross-section of the specimen were determined corresponding to the line $A-A$ in Figure 5 before and after EDT. EDT was performed in the direction «from the center to the edges» (arrow in Figure 5), using an electrode device (ED), equipped with a tungsten electrode of VL grade with a hemispherical working end, and the EDT mode provided a stored energy of the capacitor E_s up to 600 J at a single electrodynamic effect.

The treatment of specimens was performed by the electrode device in the conditions of «rigid fixation», for realization of which before EDT both sides of the specimen (Figure 5) were «rigidly» fixed by a distributed load on the assembly plate, excluding the probable angular deformations of the specimen. Such a scheme of fixation of the treated metal, on [6], provides the maximum efficiency of electrodynamic effect at other equal parameters of the EDT mode. The treatment was performed at the value of ED inductance $L = 5.3 \mu H$ and the energy $E_s < 1 kJ$. When choosing the values of the charging voltage U for two EDT schemes, the researchers were based on the fact that the values of $U_I + U_P$ for a single-channel scheme and the total $U_I + U_P$ for a two-channel scheme should be equal. Thus, in a single-channel scheme the EDT mode was used, which is set as follows $U_{I+P} = 570 V$ ($I = 5.75 kA$) for PEC $I + P$, and in a two-channel scheme $U_P = 200 V$ ($I_P = 1.45 kA$) for PEC P and $U_I = 370 V$ ($I_I = 4.3 kA$) for PEC I .

To realize the electrodynamic effect on the working part of the specimen in the EDT zone, ED was installed and its guaranteed electrical contact with the treated surface was provided when the discharge circuit was closed. The switching of the power key initiated the discharge of the capacitive energy storage through ED into the treated material. In the process of

performing EDT with a series of PEC, ED was moved along the surface of the treated area of specimens in the direction «from the center to the edges» (arrow in Figure 5) with a step of 3–5 mm. In each EDT cycle, up to 35 electrodynamic effects were performed, which provided a uniform surface electroplastic deformation of the treated weld area (fusion line) with a length of 90 mm. On one- (Figure 1) and two-channel (Figure 3) schemes of EDT, different schemes of specimens treatment were realized, which were performed from the outer surface of the weld and the fusion line, as well as from the root side of the weld.

The fatigue tests of the specimens were performed, which were treated on different EDT schemes. The machine of the grade UPM-02 was used (Figure 4), which realizes the scheme of fatigue bending tests (Figure 4, b) at a symmetrical load cycle with a frequency of 14 Hz. The amplitude of the loading cycle σ_a was set in the range of 80–160 MPa, and the loading was carried out during the incubation period [7] until the number of cycles N was registered, corresponding to the beginning of the fracture of the specimens. The effect of different EDT schemes on the cyclic life N of specimens was investigated.

Analysis of the obtained results. The distribution of σ_x before and after the double-sided EDT of the weld center on the single-channel scheme is presented in Table 2. Table shows that before EDT the peak values of tensile stresses close to $\sigma_{0.2}$ for AMg6 alloy in the weld center and on the fusion line (in the zones of a probable fracture), after treatment were transformed into compressive stresses, the values of which reached $-10 MPa$.

The values of σ_y stresses in the center of the weld and on the fusion line before EDT on a single-channel scheme reached 12 and 17 MPa, respectively. After EDT, σ_y were transformed into compressive stresses, the values of which in the center of the weld and on the fusion line reached -68 and $-56 MPa$, respectively.

The features of schemes, location of the fracture zones and the value N are presented in Table 3. From its data it can be seen that as a result of double-sided EDT of the outer surface and the root of the weld on a single-channel scheme of ED, the cyclic life N of the specimens of welded joints in the studied range of σ_a is three times increased (lines 4, 7, 8) as compared to the original one (lines 1–3). The fracture of both the original specimens as well as those, which were treated, occurs along the fusion line. The data of Table 3 for a single-channel scheme confirm the results of fatigue tests, presented in Table 4.

The additional EDT of the base metal at a distance of 10 mm from the fusion line (line 5) provides a more developed zone of compressive stresses in the area of predicted fracture of specimens. Increase in the compression zone created in the vicinity of the welded

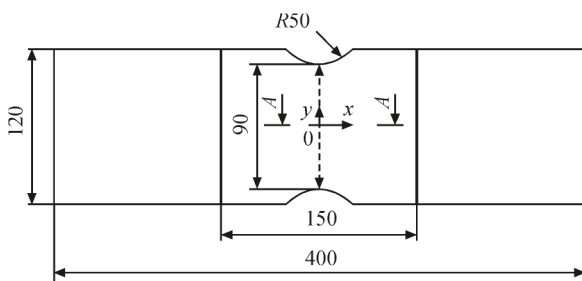

Figure 5 Scheme of specimens of welded joint of AMg6 alloy for fatigue tests, where the dashed arrow indicates the direction of EDT, $A-A$ is the cross-section, in which the stresses σ_x and σ_y were determined

Table 2 Distribution of σ_x before and after EDT (Figure 5) on a single-channel scheme

X , mm	0	5	11	16	25	36	46	56	66	76
σ_x before EDT, MPa	120	130	100	40	-40	-38	-28	-21	-18	-10
σ_x after EDT, MPa	-8	-9	-10	-10	5	18	15	11	2	-7

joint does not affect the life N . At the same time, a preliminary cyclic loading of the specimens before reaching $N_1 = 400000$ before EDT (line 6) leads to an increase in the life N . Comparing the data of lines 6 and 1 of Table 3, it can be seen that a preliminary cyclic stimulation of the specimens three times increases their life. This fact can be explained by the additional relaxation of residual welding stresses, which is provided by a preliminary cyclic loading of the specimens to the value N_1 . Thus, the efficiency of EDT can be increased during the treatment of the welded joints, which are operated under cyclic loads, as compared to the manufactured ones.

The use of double-sided EDT using a two-channel scheme of ED has a positive effect on the life N , the value of which at $\sigma_a = 160$ MPa after a one- and double-sided EDT of the weld are increased by 6 and 15 %, respectively (lines 11 and 12 in Table 3) as compared to a single-channel one (line 8). The fracture zone is shifted to the base metal by 5–10 mm from the fusion line. The comparison of the lines 8 and 12 is interesting provided by the fact that the increase in N during the use of a two-channel scheme was achieved due to the realization of a twice lower number of effects than that used during a single-channel one (excluding EDT on the side of the weld root).

The additional EDT of the fusion line (line 13) increases the value of N twice as compared to a single-channel treatment of the weld alone (line 8) and

five times as compared to the original one (line 3). The increase in the N values during the use of a two-channel scheme can be explained by the peculiarities of a controlled synchronization of the components of an electrodynamic effect, which eliminates the passage of PEC through the treated metal in the phase of attracting the disk 16 to the coil 14 (Figure 3, *a*). This eliminates the thermal effect of PEC during the period of breaking the electric contact of the discharge circuit, which leads to the strengthening of the treated metal to a level higher than that of the base one. This results in shifting of the fracture zone from the fusion line into the base metal, which is shown in Table 3 (lines 9, 11).

The impact of the current component of the electrodynamic effect (PEC I) on the life N of welded joints during EDT on a two-channel scheme of ED was studied. For this purpose, the specimens were studied, that were treated under the conditions of interaction of electropulsed and dynamic effects (PEC I + PEC P — line 9), as well as only under dynamic effect (PEC P — line 10). From the Table 3 it follows that the value N under the conditions of interaction is more than 50 % higher than under dynamic loading. This fact can be explained by the contribution of the current component of EDT, which initiates the contribution of the electroplastic effect (EPE) [8] in reducing the level of residual welding stresses. The effect of stresses on the life N is especially significant at a multicyclic load, which corresponds to $2\sigma_a = 80$ MPa. The factor that determines the increase of

Table 3 Values of life N at different amplitude of cycle $2\sigma_a$ of welded joints of AMg6 alloy after EDT on one- and two-channel schemes of ED

Number of specimen series	EDT scheme	$2\sigma_a$, MPa	N	Fracture zone
1	Without EDT	80	525600	Along the fusion line
2	Same	120	210600	Same
3	»	160	151200	»
4	Single-channel, double-sided (weld + root)	80	1004800	»
5	Single-channel, double-sided (weld + root + BM on both sides at a distance of 10 mm from the fusion line)	80	970000	Base metal (BM) at 2 mm from the fusion line
6	Similarly to No.5, before EDT the specimen was loaded $N_1 = 400000$ at $\sigma_a = 80$ MPa	80	932000, taking into account $N_1 = 1332000$	Along the fusion line
7	Single-channel, double-sided	120	568000	Same
8	Same	160	360600	»
9	Two-channel: PEC I + PEC P (double-sided)	80	1169320	BM at 5 mm from the fusion line
10	Two-channel: PEC P (double-sided)	80	752400	Along the fusion line
11	Two-channel PEC I + PEC P (one-sided)	160	382000	BM at 10 mm from the fusion line
12	Two-channel: PEC I + PEC P (double-sided)	160	414000	Weld center
13	Two-channel: PEC I + PEC P (double-sided — weld + fusion line)	160	718000	Along the fusion line

Table 4 Results of fatigue tests of specimens of AMg6 alloy welded joints (Figure 4) at $\sigma_a = 80, 120$ and 160 MPa in the coordinates $2\sigma_a - N$ for single-channel scheme

Initial state — before EDT							
N	520000	470000	460000	210000	150000	130000	140000
$2\sigma_a, \text{MPa}$	80	80	80	120	160	160	160
After EDT							
N	1000000	1050000	1040000	560000	360000	390000	392000
$2\sigma_a, \text{MPa}$	80	80	80	120	160	160	160

N during the realization of EPE is also the deformation strengthening of the weld on the basis of electric stimulation, which explains the displacement of the fracture zone from the fusion line into the base metal.

It should be noted that namely at a small amplitude of the cycle $2\sigma_a = 80$ MPa the level of residual welding stresses has the greatest effect on the value of N . When comparing the initial N (line 1) with its values obtained after EDT on one- (line 5) and two-channel (line 9) schemes of ED, the dominance of the latter as a tool that provides the greatest increase in N can be seen. At the same time, the preliminary cyclic loading, which helps to reduce the level of residual welding stresses before the beginning of EDT, provides an increase in N as compared to the specimens treated without a preliminary force effect. This fact gives grounds to assume that the preliminary load is the factor increasing the life of welded joints during the use of EDT, which in the future may be the subject of special investigations.

When comparing the effect on the life of EDT on a two-channel schemes of ED that realize the effect of PEC I (line 10) and PEC $I + \text{PEC } P$ (line 9), it can be seen that the contribution of the current action increases N . The increase in the contribution of the current component into the electrodynamic effect, which is performed on the scheme PEC $I + \text{PEC } P$ and intensifies the manifestation of the electroplastic effect, seems to be promising and quite simply realized on the considered element base.

The carried out investigations showed the effectiveness of EDT of AMg6 alloy and its welded joints in increasing the resistance to fracture under cyclic loads in the conditions of symmetrical bending. The use of EDT of the base metal [6], welded joints, as well as elements of thin-sheet structures in the area of expected fractures will allow increasing the service life of manufactured products and those, operating under cyclic loads.

Conclusion

1. It is shown that electrodynamic treatment (EDT) of specimens of butt welded joints of AMg6 alloy leads to a decrease in the level of residual tensile welding stresses, which is accompanied by their transition to compression stresses.

2. It was established that as a result of double-sided single-channel EDT of the surface of welded joints of AMg6 alloy, the cyclic life is three times increased as compared to the initial one. The additional EDT of the fusion line five times increases the life as compared to the untreated metal.

3. According to the results of comparative evaluation of single-channel and double-channel EDT of welded joints of AMg6 alloy, it was established that the increase in life during the use of a two-channel scheme (as compared to a single-channel one) is determined by a controlled synchronization of electrodynamic components, which excludes passing of PEC in the phase of its attenuation through the treated metal.

4. It was established that the life of the specimens treated on a two-channel scheme during electropulsed action, is more than 50 % higher than during dynamic action, which is associated with the contribution of the electroplastic effect in reducing the level of residual welding stresses.

1. Knysh, V.V. (2014) Determination of cyclic life of structure elements in arresting fatigue cracks. *The Paton Welding J.*, 69–71.
2. Knysh, V.V., Klochkov, I.N., Pashulya, M.P., Motrunich, S.I. Increase of fatigue resistance of sheet welded joints of aluminium alloys using high-frequency peening. *Ibid.*, 5, 22–29.
3. Finkel, V.M., Ivanov, V.M., Golovin, Yu.I. (1983) Crack healing in metals by crossed electric and magnetic fields. *Problemy Prochnosti*, 4, 54–58 [in Russian].
4. Lobanov, L.M., Pashchin, N.A., Solomijchuk, T.G. et al. (2012) Changes of structure of AMg6 aluminium alloy in electrodynamic effects. *Visnyk Ukrainського Material. Tovarystva*, 5, 30–42 [in Russian].
5. Lobanov, L.M., Pivtorak, V.A., Savitsky, V.V., Tkachuk, G.I. (2006) Procedure for determination of residual stresses in welded joints and structural elements using electron speckle-interferometry. *The Paton Welding J.*, 1, 10–13.
6. Lobanov, L.M., Pashchin, N.A., Yashchuk, V.A., Mikhodui, O.L. (2015) Effect of electrodynamic treatment on the fracture resistance of the AMg6 aluminum alloy under cyclic loading. *Strength of Materials*, 3, 91–98.
7. Yakovleva, T.Yu. (2003) *Local plastic deformation and fatigue of metals*. Kiev, Naukova Dumka [in Russian].
8. Baranov, Yu.V., Troitsky, O.A., Avramov, Yu.S. (2001) *Physical principles of electropulsed and electroplastic treatments and new materials*. Moscow, MGIU [in Russian].

Received 13.03.2020