

## UNIT FOR HIGH-VELOCITY ELECTRIC ARC SPRAYING

- > The unit is designed for deposition of wear, corrosion resistant and special coatings, repair of worn machine parts by means of double-wire electric arc spraying in high-velocity flow of hot combustion products of hydrocarbon gas with air of current-conducting materials in form of wire (flux-cored wire) of 1.6–2.2 mm diameter. Joint development of PWI and «PLAZER» Company.

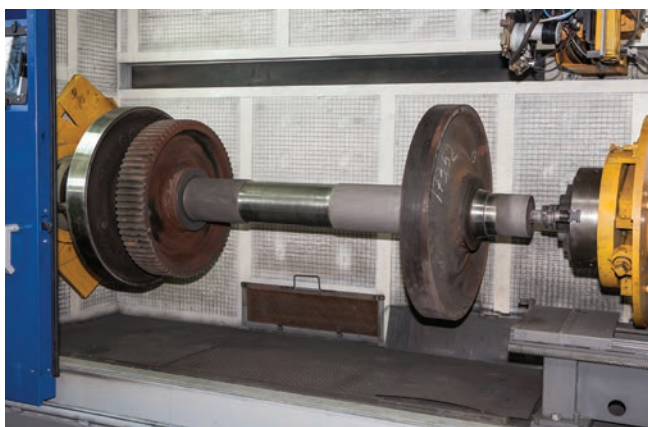

Block of high-velocity electric arc metallizer

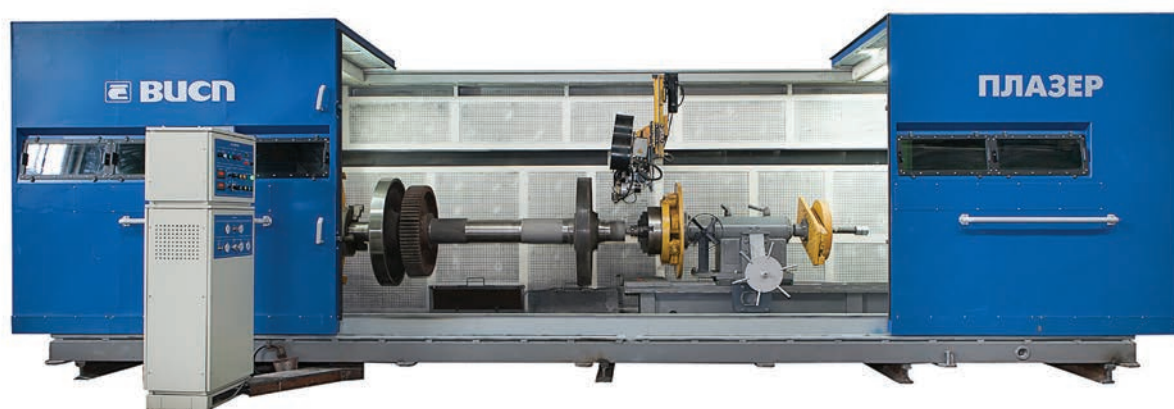
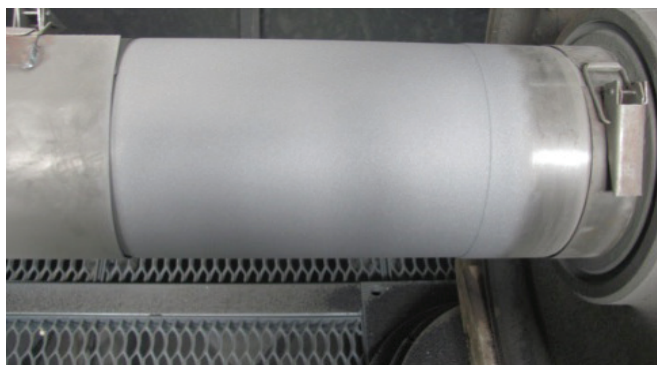

Appearance of restored part and unit in the framework of semi-automatic line

Developed by PWI